

BLN100 1 GHz Fiber Deep Node

STARLINE® Series



Motorola's 1 GHz STARLINE® BLN100 is backwards compatible with the substantial installation of General Instrument/Motorola Broadband Line Extender (BLE) amplifier housing base. The benefit of the BLN100 is to easily convert existing amplifier locations to optical nodes by extending fiber outward from the main node or splice enclosure. This type of node segmentation using satellite or fiber deep nodes is an incremental step towards extending fiber closer to the premise, leveraging the existing HFC infrastructure to deliver higher bandwidth per subscriber.

The BLN100 optical node is an essential building block in evolving Hybrid Fiber Coaxial (HFC) network architectures enabling amplifier to node conversions.

KEY FEATURES

The BLN100 Fiber Deep node supports multi-wavelength solutions in both the forward and return path. By combining multiple wavelengths onto a single fiber, operators are able to free up fibers for other revenue generating applications at the same time they perform node segmentation. In the forward path, a ruggedized demultiplexer at the original node or splice enclosure location is used to separate the wavelengths onto individual fibers. These new fibers are pulled to previous BLE amplifier locations that can now be converted to an optical node by removing the existing amplifier electronics chassis and housing lid and replacing it with the BLN100 electronics chassis and housing lid. WDM devices within the BLN can allow CWDM transmitters to utilize the same fiber for transmission back to the splice enclosure.

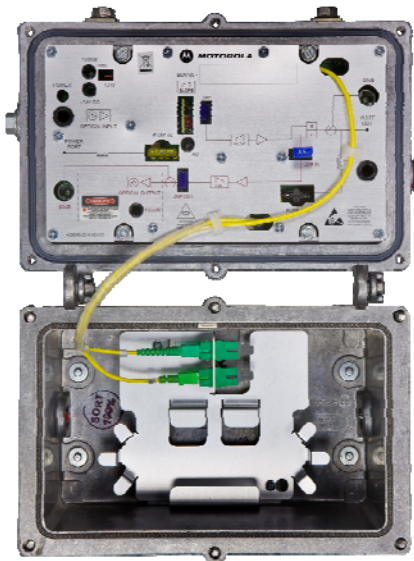

BENEFITS INCLUDE:

- 1003 MHz Gallium Arsenide (GaAs)
- Single integrated optical receiver
- 46 dBmV RF output @ 550 MHz w/ -3 dBm input
- Multiple diplex filter options
- N-split (5-85/104-1003 MHz) availability
- Ease of set-up and ergonomics
- Integrated thermal compensation
- 60/90 V powering
- Standard FTEC surge protection
- SC/APC Connectorization
- 10 Ampere AC capability
- Plug-in Return Transmitter
- 1310nm 0.4 mW to CWDM 2.0 mW transmitters available
- User friendly fiber management

Motorola, Inc.
101 Tournament Drive
Horsham, PA 19044
www.motorola.com/broadband



MOTOROLA, the Stylized M Logo, STARLINE, Mini-Bridger, and LIFELINE are registered in the US Patent & Trademark Office. All other product or service names are the property of their respective owners.
© Motorola, Inc. 2006. All rights reserved.

03.09.09
Rev 1

Specifications are subject to change without notice.

FORWARD PATH

The BLN100 produces approximately 55 dB of gain through an integrated optical receiver and high-gain power-doubled hybrid that both use Gallium Arsenide (GaAs) technology. Typical RF output levels of 46 dBmV @ 550 MHz are achieved with an optical input power of -3 dBm. This allows operators to overcome the optical demux passive loss and still maintain the existing amplifier output levels after the optical upgrade. Installation is simplified by a 1V/mW DC test point that can be scaled for accuracy for either 1310 or 1550 nm installations. A plug-in Linear Mid-Stage Equalizer (LME) and flatness slope board develop the BLN100 output slope so that it precisely matches the previous amplifier slope. A single RF -20 dB test point allows technicians to easily determine proper set-up levels by selecting the proper forward path JXP attenuator value so no additional load balancing is required at subsequent active locations. The BLN100 has an integrated thermal compensation circuit that maintains output level stability over the operating temperature range. No user adjustment is required.

POWERING

The BLN100 can be powered from either the input or output port. The input port features a 75-ohm RF termination that effectively terminates the cable span ahead of the converted amplifier location.

Fuses direct ac from the ports to the BLN100 power supply which is protected by a Fast Transfer Electronic Crowbar (FTEC) surge protector. The input and output ports are rated for 10A power passing. A LED provides a visual indication when the BLN100 power supply is producing 24V and the node is on. Separate AC and DC test points are provided as additional measurement and troubleshooting aids.

Worst-Case Plant Power Draw is shown below:

	Node
	BLN100 w/ CWDM Transmitter
AC input	AC Amps
@ 90 VAC	0.90
@ 75 VAC	1.02
@ 60 VAC	1.20
@ 53 VAC	1.14
@ 45 VAC	1.21
@ 38 VAC	1.30

RETURN PATH

The BLN100 return path can be configured with a single plug-in return transmitter. 5 models of transmitters are available based on network requirements:

1310 nm	IFPT	400 μ W	Isolated Fabry-Perot Transmitter (-4 dBm)
1310 nm	EIFPT	1 mW	Enhanced Isolated Fabry-Perot Transmitter (0 dBm)
1310 nm	DFBT	1 mW	Distributed Feedback Transmitter (0 dBm)
1310 nm	DFBT3	2 mW	Distributed Feedback Transmitter (+3 dBm)
1271 nm – 1611 nm	DFBT3	2 mW	Course Wave Division Multiplexed (CWDM) Distributed Feedback Transmitter (+3 dBm)

The BLN100 is designed to accommodate a 28 dBmV total power input to the node. The return path features a -20 dB RF test point and two JXP attenuation locations to properly adjust the total power to the proper laser input level. An RF active amplifies the signal level prior to the transmitter and a Return Path Low Pass Filter (RPLPF) provides additional rejection of forward path energy on the laser input. There is no Ingress Control Switch (ICS) option on the BLN100.

FIBER MANAGEMENT

The BLN100 housing lid has an extended depth over the normal amplifier lid to accommodate two fiber service cable entries, one on each side of the housing lid. A fiber tray and bulkhead optical connectors accommodates fiber management and ruggedized passive devices. The BLN100 is available with SC/APC connectors only.

ELEMENT MANAGEMENT

There is no status monitor transponder option for the BLN100. As node sizes decrease, the possibility of widespread service outages also decreases. This is consistent with the lower cost, non-redundant BLN100 feature set. Motorola offers status monitoring on the full featured SG4000 and MBN100.

BLN100 Specifications

All specifications stated as worst-case over temperature unless otherwise noted.

SPECIFICATIONS

OPTICAL RECEIVER

Optical Wavelength	1290 - 1610 nm
Optical Input Power Range	-3.0 to +2.0 dBm continuous
Optical Connector Type	SC/APC
Optical Input Return Loss	45 dB minimum

RF

Operational Bandwidth	F_{min} to 1003 MHz
Flatness	± 0.75 dB F_{min} to 1003 MHz
Output Slope	8, 10, 12, 14.5, 16, 18 dB
Level Stability	± 1.5 dB over operating temperature range
RF Output Test Points	-20 \pm 0.5 dB (internal)
RF Output Impedance	75 ohm
RF Output Return Loss	16 dB minimum

STATION PERFORMANCE

Output Level	46 dBmV @ 550 MHz with -3 dBm optical input power
Power Consumption	33 W maximum
Hum Modulation @ 10 A	-60 dBc

AC Bypass Current	10 A
-------------------	------

Measured with 79 channels NTSC at 46 dBmV @ 547.25 MHz with digital loading 6 dB below analog, 550 to 1003 MHz, 20 km optical link, 0 dBm optical input power, GX2 transmitter

Composite Triple Beat (CTB)	-66 dBc
Composite Second Order (CSO)	-63 dBc
Carrier to Composite Noise (CCN)	50 dB

MECHANICAL/ENVIRONMENTAL

Dimensions	10.9"L x 8.0"W x 6.3"D (27.6 L x 20.3 W x 16.0 D cm)
Weight	7.5 lbs (3.4 kg)
Mounting	Aerial or pedestal
RF Connector Types	SCTE-compliant housing, accepts 1.6" 5/8 stinger
Operating Temperature Range	-40 °F to 140 °F (-40 °C to 60 °C)

Motorola, Inc.
101 Tournament Drive
Horsham, PA 19044
www.motorola.com/broadband



MOTOROLA, the Stylized M Logo, STARLINE, Mini-Bridger, and LIFELINE are registered in the US Patent & Trademark Office. All other product or service names are the property of their respective owners.
© Motorola, Inc. 2006. All rights reserved.

03.09.09
Rev 1

Specifications are subject to change without notice.

BLN100 Block Diagram

BLN100 Block Diagram

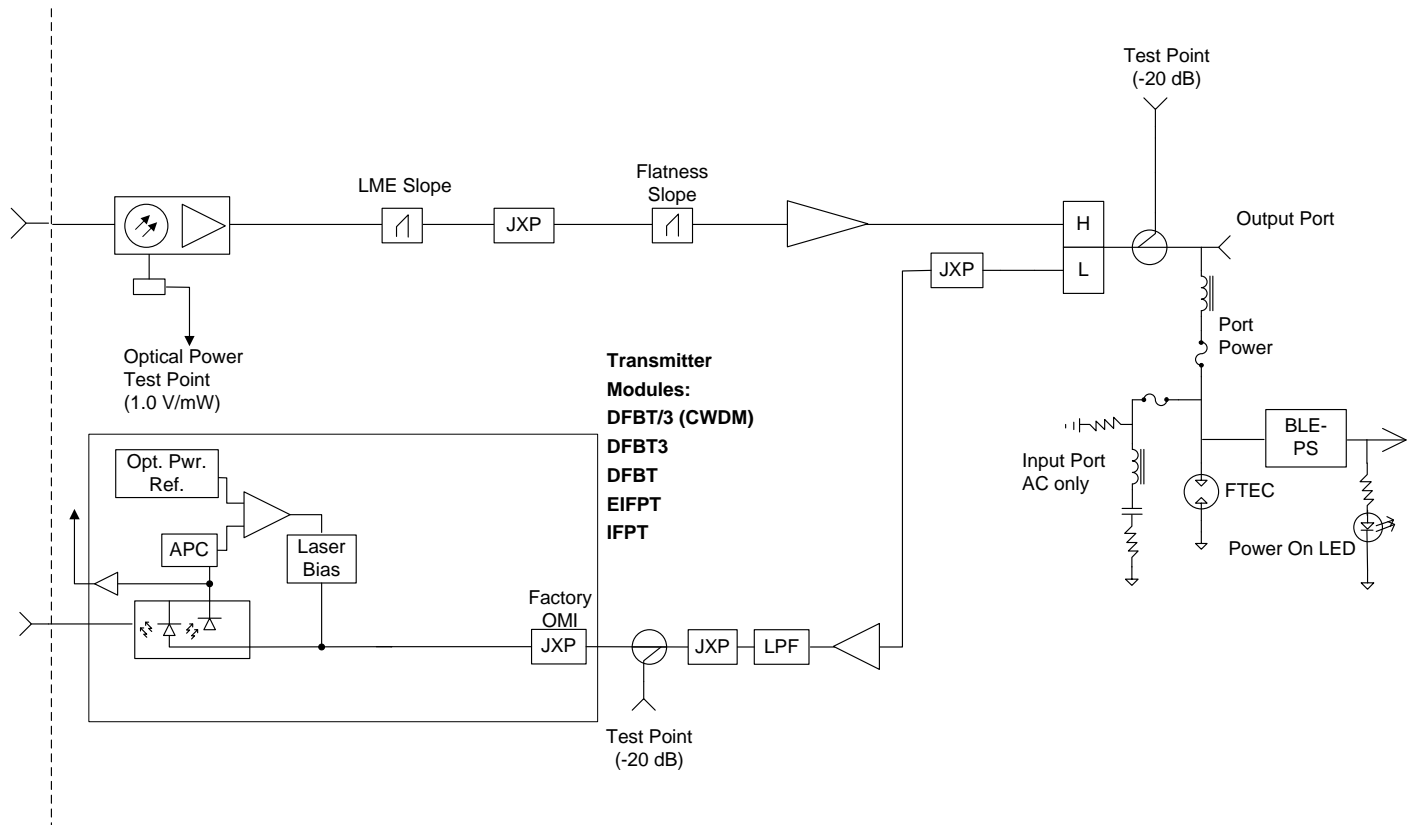

BLN100 Ordering Information

Part Number	Model	Description
812000-001-00	BLN100-SK/1550	1 GHz node electronics & housing with 14 dB slope, 5-42/54-1GHz, power supply, integrated receiver, FTEC, DFBT3 2.0 mW 1551 nm return transmitter
812000-002-00	BLN100-SS/1550	1 GHz node electronics & housing with 14 dB slope, 5-40/52-1 GHz, power supply, integrated receiver, FTEC, DFBT3 2.0 mW 1551 nm return transmitter
812000-005-00	BLN100-SN/1550	1 GHz node electronics & housing with 14 dB slope, 5-85/104-1 GHz, power supply, integrated receiver, FTEC, DFBT3 2.0 mW 1551 nm return transmitter
812000-003-00	BLN100-SK/DFBT	1 GHz node electronics & housing with 14 dB slope, 5-42/54-1GHz, power supply, integrated receiver, FTEC, DFBT 1.0 mW 1310 nm return transmitter
812000-004-00	BLN100-SS/DFBT	1 GHz node electronics & housing with 14 dB slope, 5-40/52-1GHz, power supply, integrated receiver, FTEC, DFBT 1.0 mW 1310 nm return transmitter
812000-006-00	BLN100-SN/DFBT	1 GHz node electronics & housing with 14 dB slope, 5-85/104-1GHz, power supply, integrated receiver, FTEC, DFBT 1.0 mW 1310 nm return transmitter
812000-010-00	BLN100-SK/NONE	1 GHz node electronics & housing w/ 14 dB slope, 5-42/54-1GHz, power supply, integrated receiver, FTEC, NO RETURN TX
812000-011-00	BLN100-SS/NONE	1 GHz node electronics & housing w/ 14 dB slope, 5-40/54-1GHz, power supply, integrated receiver, FTEC, NO RETURN TX
812000-012-00	BLN100-SN/NONE	1 GHz node electronics & housing w/ 14 dB slope, 5-85/104-1GHz, power supply, integrated receiver, FTEC, NO RETURN TX

Transmitters and Accessory Model

555864-001-00	BLN-IFPT/SC-R	BLN-IFPT/SC-R, Isolated, uncooled IFPT return path TX, 0.4 mW, 1310 nm, SC/APC, ROHS COMPLIANT, FINISHED GOOD
555864-002-00	BLN-EIFPT/SC-R	BLN-EIFPT/SC-R, Isolated, uncooled EIFPT return path TX, 1 mW, 1310 nm, SC/APC, ROHS COMPLIANT, FINISHED GOOD
555864-003-00	BLN-DFBT/SC-R	BLN-DFBT/SC-R, Isolated, uncooled DFBT return path TX, 1 mW, 1310 nm, SC/APC, ROHS COMPLIANT, FINISHED GOOD
555864-004-00	BLN-DFBT3/SC-R	BLN-DFBT3/SC-R, Isolated, uncooled DFBT3 return path TX, 2 mW, 1310 nm, SC/APC, ROHS COMPLIANT, FINISHED GOOD
555866-TAB-00	BLN-DFBT3*-CWDM/SC-R	BLN, Isolated, uncooled DFBT3 return path TX, 2 mW, 1471 nm to 1611 nm, in 20 nm spacing, SC/APC, ROHS COMPLIANT, FINISHED GOOD
928150-002-00	SG1-4 FIBER SC/APC	50' Fiber Service Cable, 4 SC/APC connectors, 42" Break out length

Motorola, Inc.
101 Tournament Drive
Horsham, PA 19044
www.motorola.com/broadband



MOTOROLA, the Stylized M Logo, STARLINE, Mini-Bridger, and LIFELINE are registered in the US Patent & Trademark Office. All other product or service names are the property of their respective owners.
© Motorola, Inc. 2006. All rights reserved.

03.09.09
Rev 1

Specifications are subject to change without notice.